



Lamello

# Cabineo



Time-saving cabinet connector with high clamping force requires NO edge-drilling

- Increase production by at least 50%
- Requires only 40-60% as much capital machinery needed for traditional dowel construction
- Reallocate up to 2/3 of former machinery operators to other profit-generating tasks
- Potentially double or triple production without a single additional hire



### 1. Dowel, Glue, Case Clamp

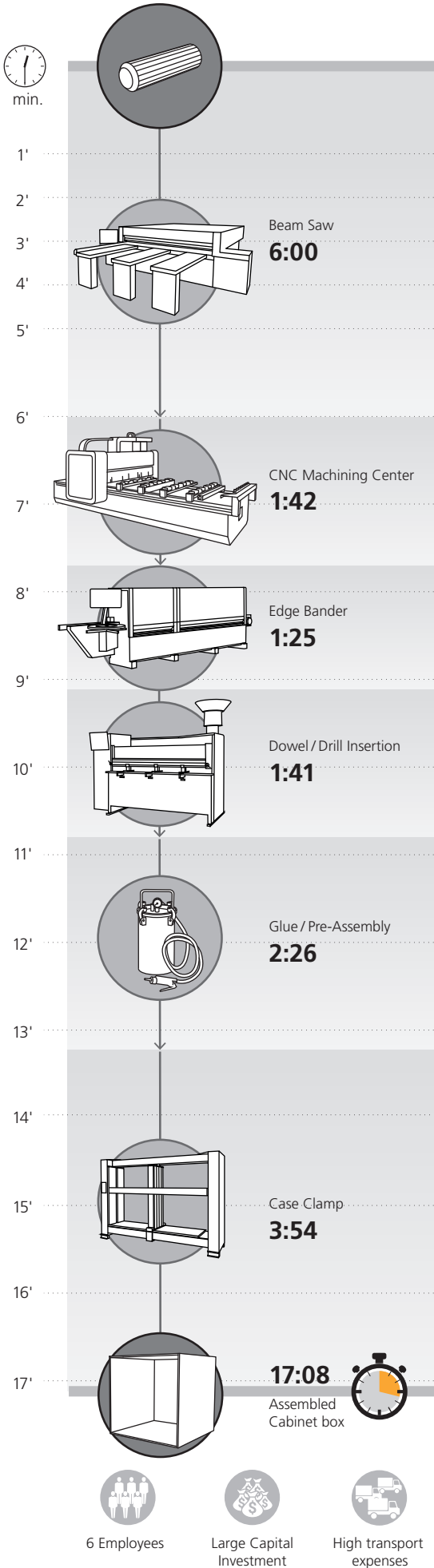

### 2. Cabineo with CNC Machining Center

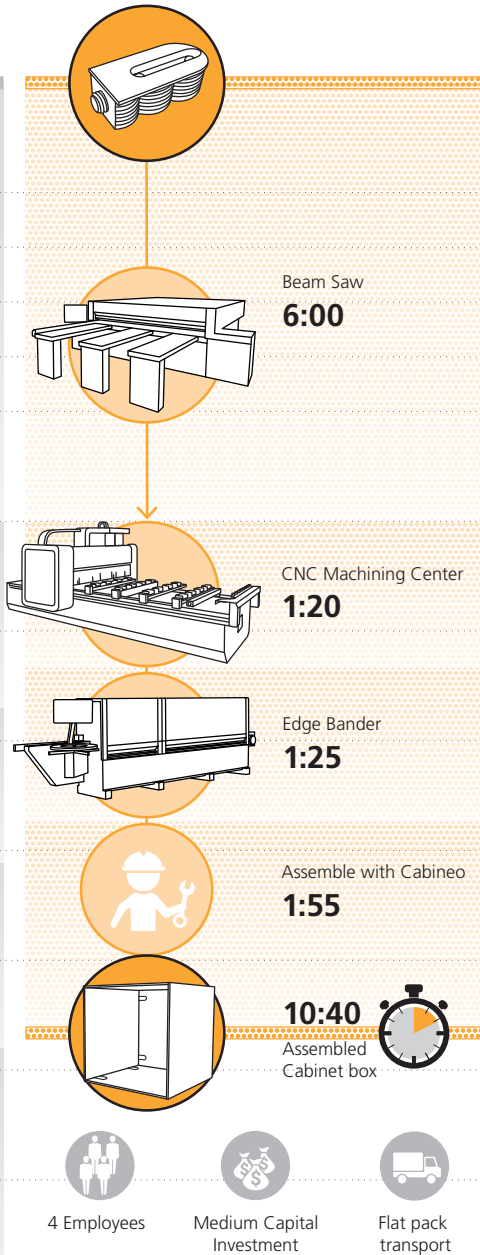

### 3. Cabineo with Nested-Base CNC Router

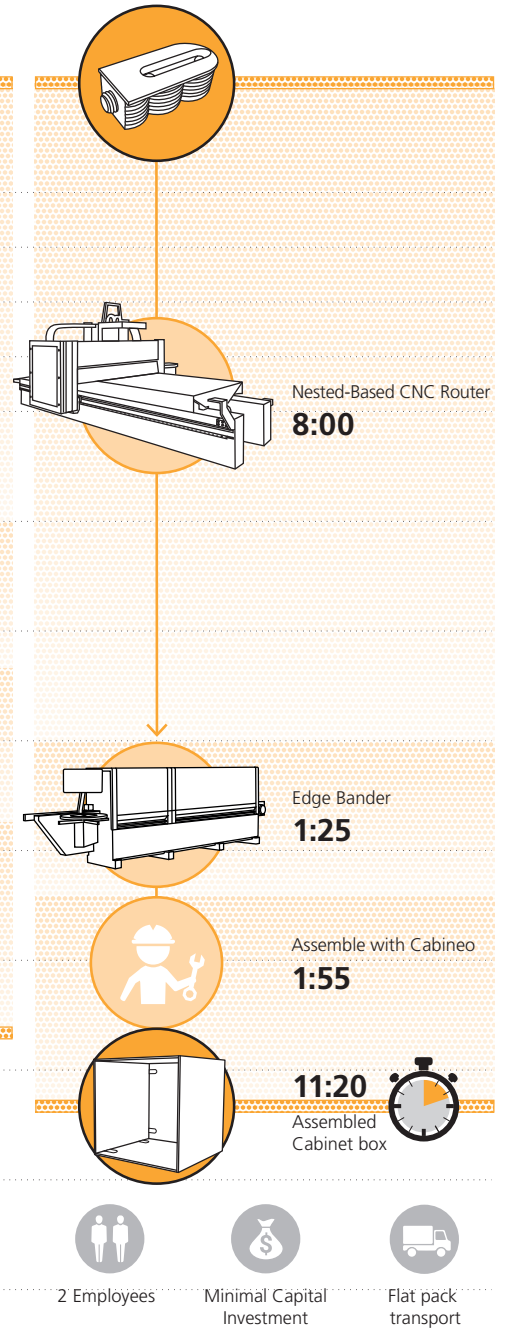

Colonial Saw Company  
 TEL 781-585-4364  
 chofmann@csaw.com